

FRENCH FITNESS

FFN-3D-SMITH / FFV-3D-SMITH

FRENCH FITNESS NEWPORT / VENICE
3D DUAL ACTION SMITH MACHINE

ASSEMBLY MANUAL



OR



FEATURES

- 11 Gauge Steel
- Commercial grade, heavy-duty steel frame
- Main tube: 50 x 75 x 3mm rectangular tube
- Secondary tube: 60 x 120 x 3mm rectangular tube
- 3D movement (up, down, backward, and forward)
- Bearing Type: Linear Ball Bushing Bearings
- Allows for 4 directional use (Up, Down, Back, & Forward)
- Smith Bar Can be locked in place in the front or back to work like a regular smith (Up and Down Movement only)
- Heavy duty adjustable safety catch bars
- Electrostatic powder-coated for superior durability
- Integrated chin up bar
- Six (6) standard weight horns
- Paint Color: Black / Silver

TECH SPECS

- Weight: 683.4lb (310kg)
- Dimensions: 76.7"L x 92.9"W x 87.4"H (L:1950mm, W:2360mm, H:2220mm)





WARRANTY





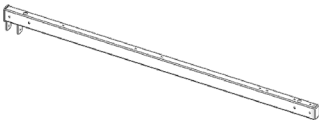
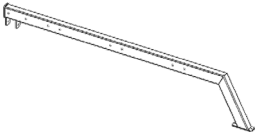
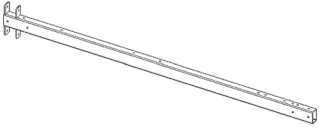

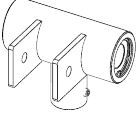
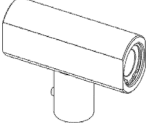
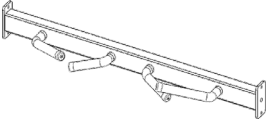
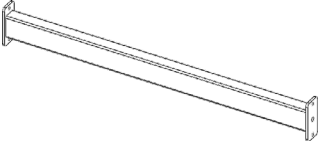
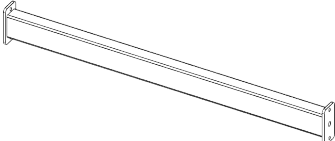
10 Years Parts, 1 Year Labor (Commercial)

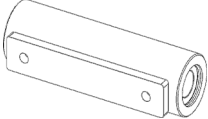
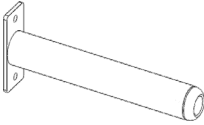
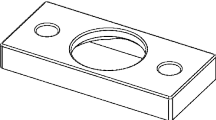
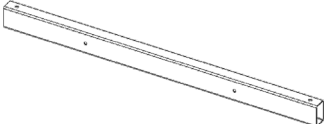
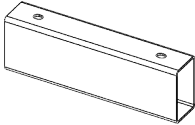
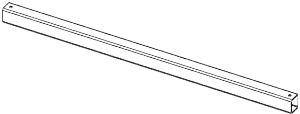
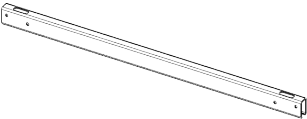
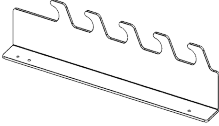
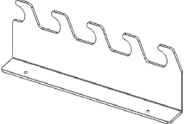
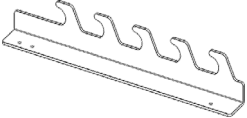
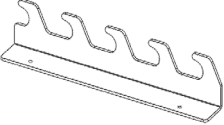
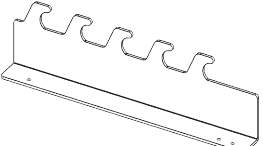
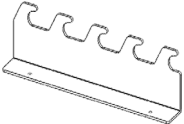
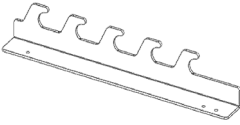
TABLE OF CONTENTS

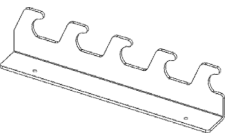
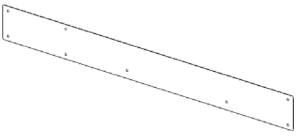
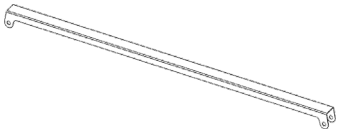
PARTS LIST (INDIVIDUALLY PACKAGED).....	4
PARTS LIST (INDIVIDUALLY PACKAGED).....	6
BLISTER PACK LIST.....	7
ASSEMBLY STEPS.....	8

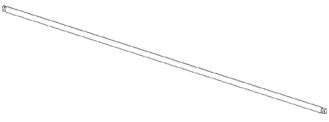
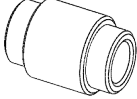
PARTS LIST (INDIVIDUALLY PACKAGED)

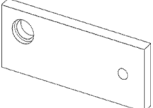

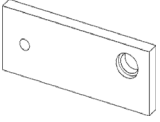





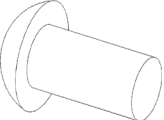
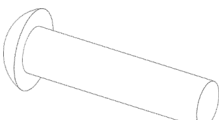
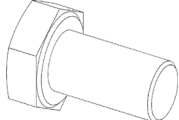

		
1	2	3
		
4	5	6
		
7	8	9
		
10	11	12
		
13	14	15
		
16	17	18
		
19	20	21
		
22	23	24

		
25	26	27
		
28	29	30
		
31	32	33
		
34		

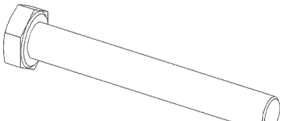
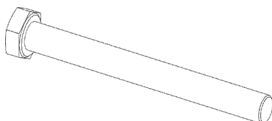
PARTS LIST (INDIVIDUALLY PACKAGED)

Item No.	Name	Quantity
1	Front riser assembly	2
2	rear support group	2
3	rear riser assembly	2
4	upper connection assembly	2
5	upper sliding group	2
6	lower sliding group	2
7	beam	1
8	rear cross member	1
9	rear cross member	1
10	recommendation component	1
11	Recommendation guide	2
12	Barbell plate set	6
13	No. 120 decorative shock-absorbing pad	6
14	lower welded pipe	2
15	short connecting pipe	2
16	linkage tube	1
17	pipe blocking	2
18	0401 stall hanging plate	1
19	0401A stall hanging plate	1
20	0402 gear mounting plate (narrow)	1
21	0402A gear mounting plate (narrow)	1
22	0408 stall hanging plate	1
23	0409 stall hanging plate	1
24	0410 gear mounting plate (narrow)	1
25	gear mounting plate (narrow)	1
26	0404 guard plate	4
27	0407 guard plate	2
28	0111 sliding track column	4
29	0204 vertical guide rod	2
30	0405 card shaft	4
31	0211 small round baffle	8
32	0114 nylon plate	4
33	No. 111 rubber ring	2
34	0114-1 nylon plate	4

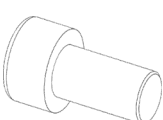
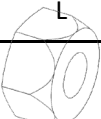
BLISTER PACK LIST

		
A	B	C
		
D	E	F
		
G	H	J
		
K	L	M
		
N	P	Q

Item No.	Name	Quantity
A	Φ8 gasket	4
B	Φ10 gasket	78
C	Φ12 gasket	2
D	M8X16L-N2 hexagon socket head screw	8
E	M8X40L-N2 hexagon socket head screw	4
F	M10X20L-W1 hexagon head bolt	8
G	M10X70L-W1 hexagon head bolt	24
H	M10X80L-W1 hexagon head bolt	2
J	M10X100L-W1 hexagon head bolt	36
K	M10X110L-W1 hexagon head bolt	2
L	M10X70L-N1 hexagon socket head screw	8
M	M10X80L-N1 hexagon socket head screw	4
N	M12X20L-N1 hexagon socket head screw	4
P	M8X7t-S1 lock nut	4
Q	M10X9t-S1 lock nut	72

ASSEMBLY STEPS

Step	Item No.	Name	Quantity
1	2	rear support group	2
	9	rear cross member	1
	12	Barbell plate set	2
	B	Φ10 gasket	4
	M	M10X80L-N1 hexagon socket head screw	4
	Q	M10X9t-S1 lock nut	4

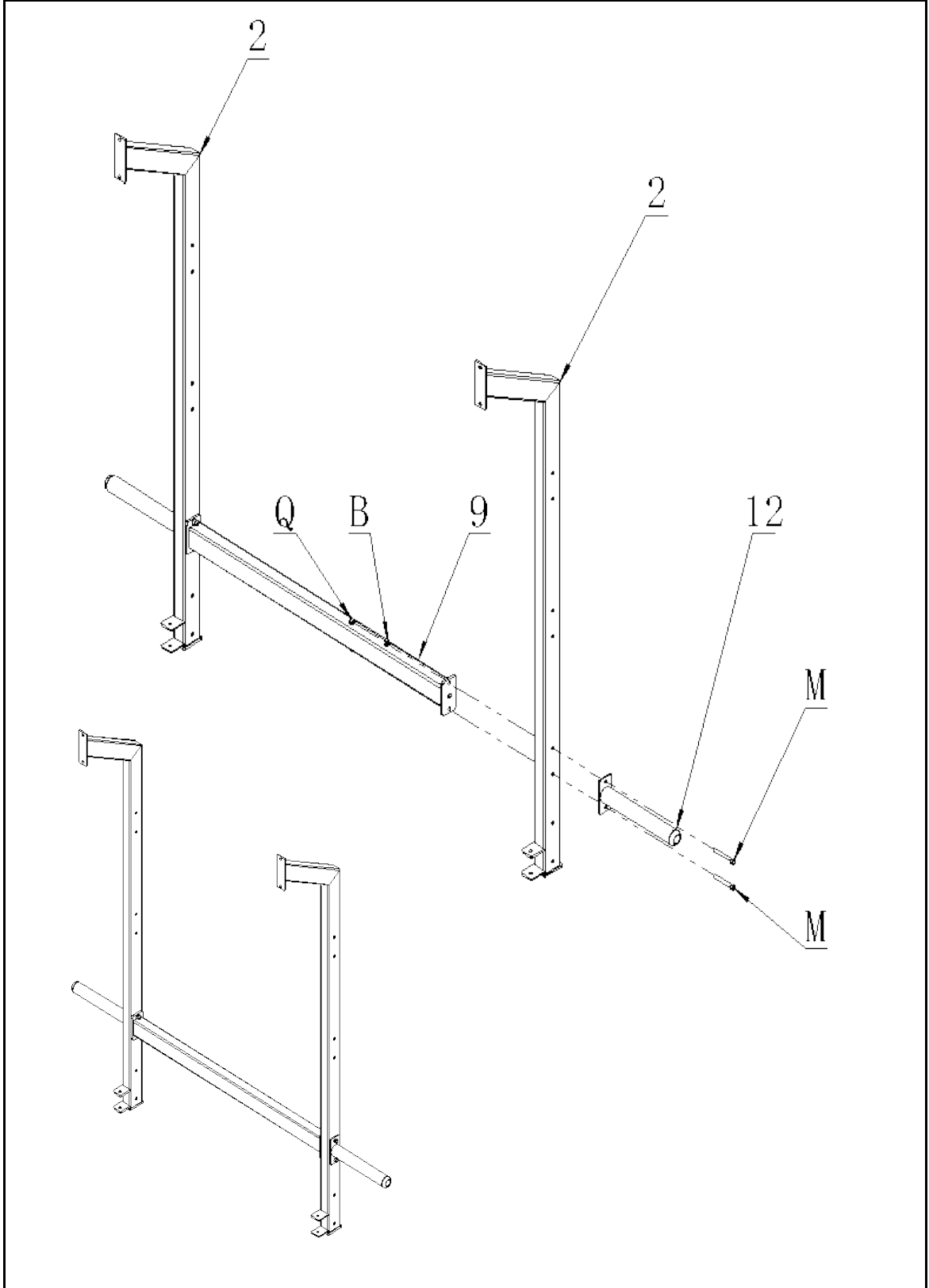

Step	Item No.	Name	Quantity
2	3	rear riser assembly	2
	15	short connecting pipe	2
	B	Φ10 gasket	6
	J	M10X100L-W1 external hexagon head bolt	6
	Q	M10X9t-S1 lock nut	6

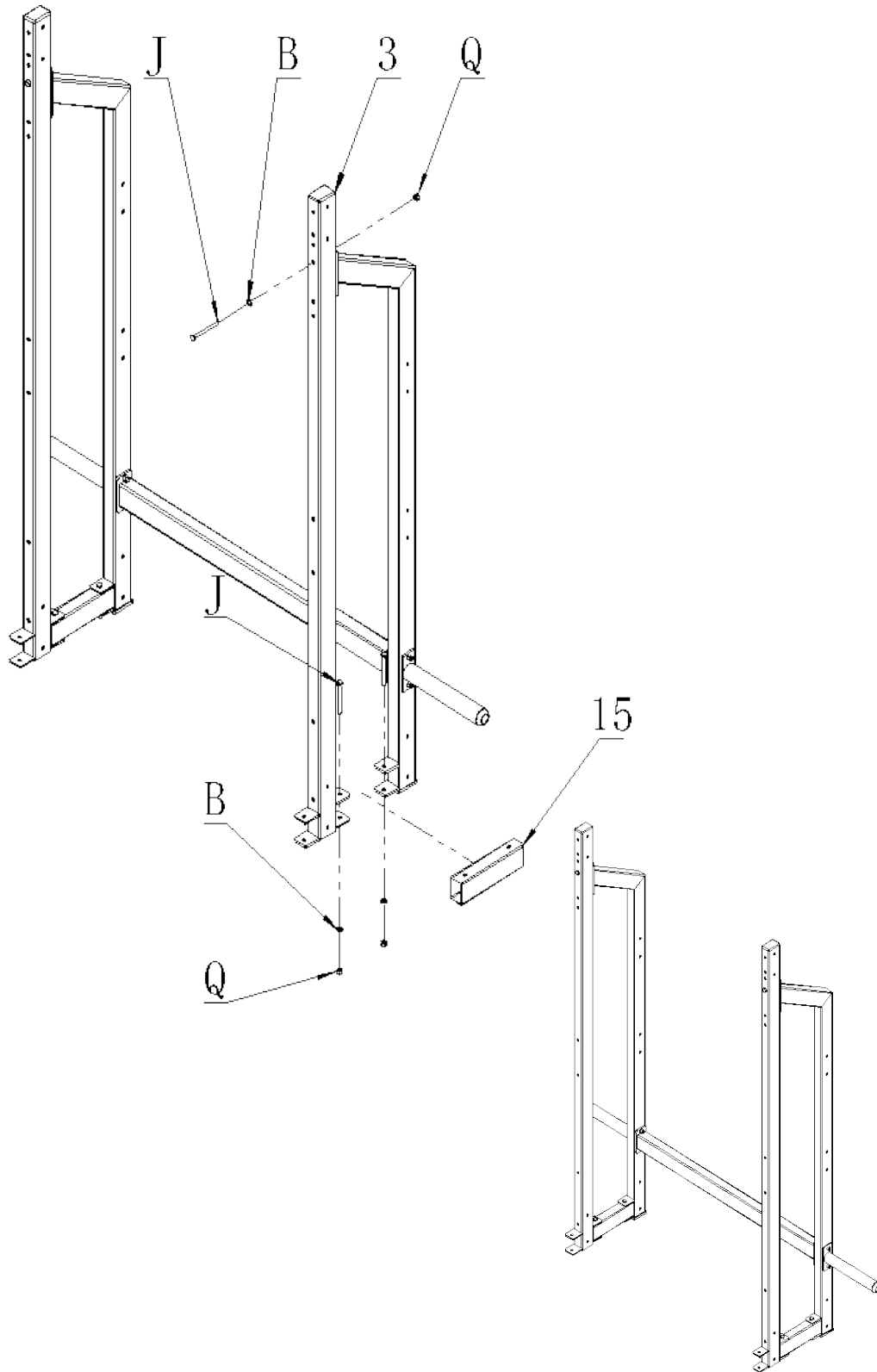

Step	Item No.	Name	Quantity
3	4	upper connection assembly	2
	14	lower welded pipe	2
	B	Φ10 gasket	6
	J	M10X100L-W1 external hexagon head bolt	6
	Q	M10X9t-S1 lock nut	4

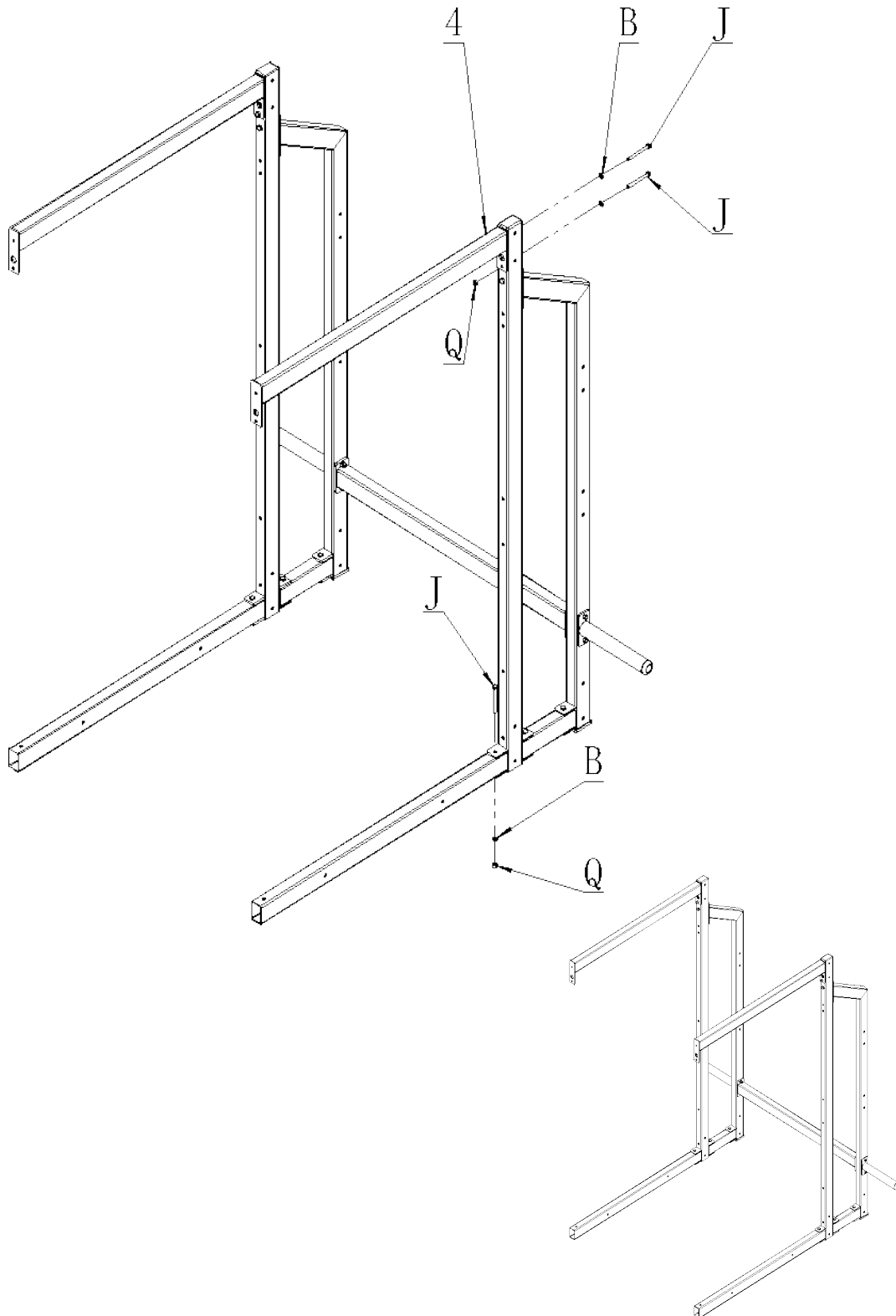

Step	Item No.	Name	Quantity
4	8	rear cross member	1
	B	Φ10 gasket	4
	G	M10X70L-W1 external hexagon head bolt	4
	Q	M10X9t-S1 lock nut	4

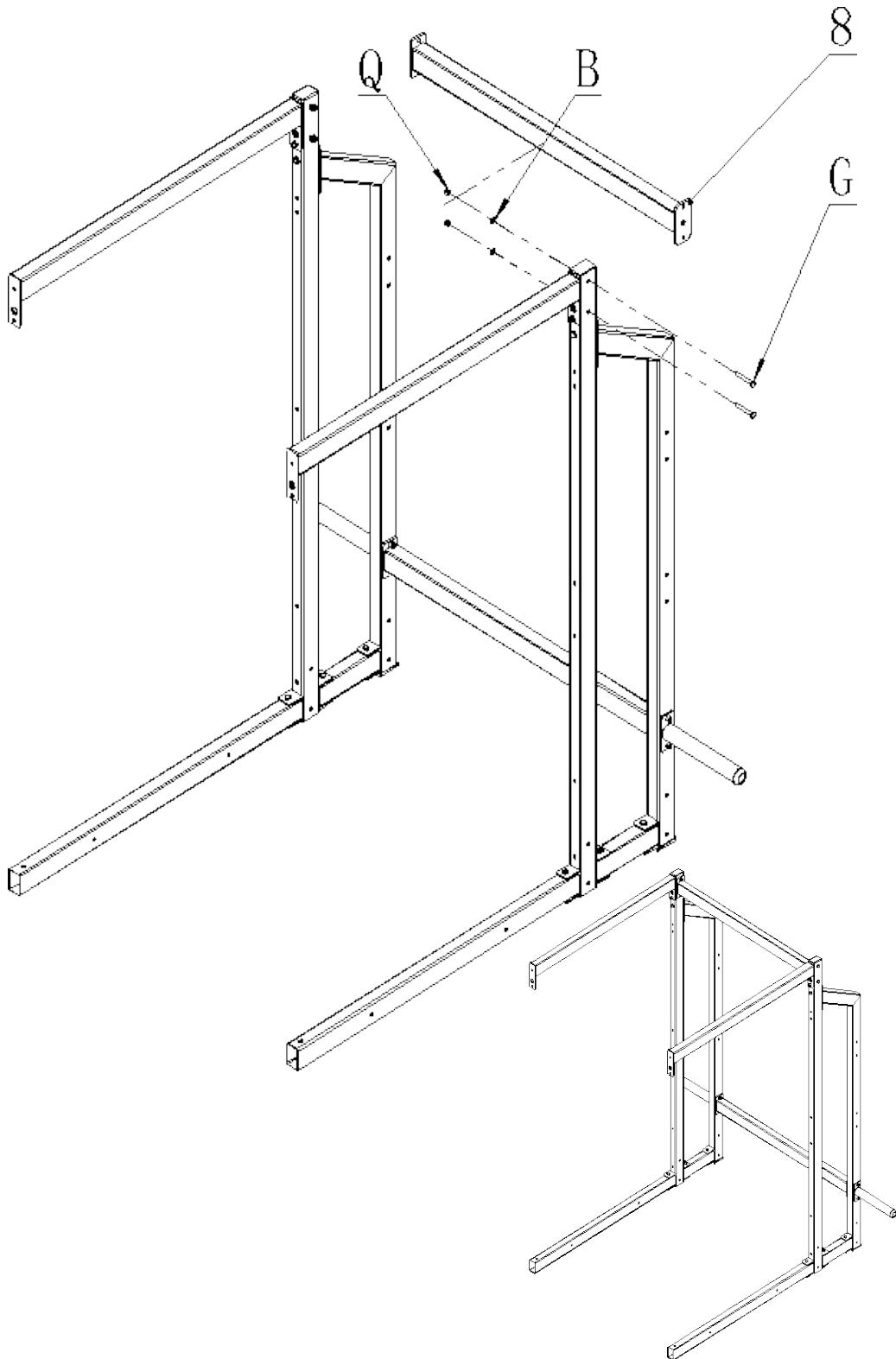

Step	Item No.	Name	Quantity
5	5	upper sliding group	2
	6	lower sliding group	2
	28	0111 sliding track column	4
	31	0211 small round baffle	4
	F	M10X20L-W1 external hexagon head bolt	4

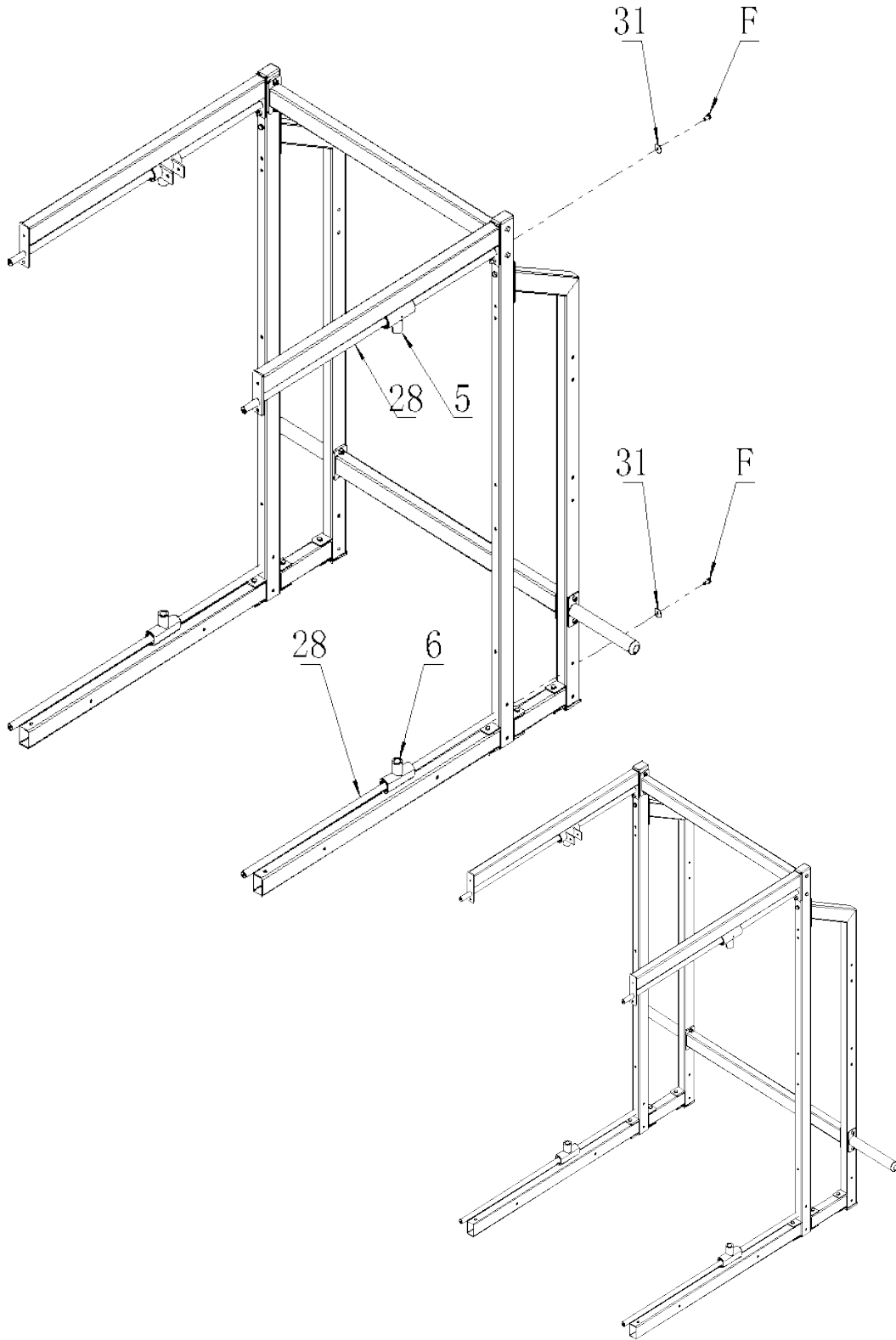

Step	Item No.	Name	Quantity
6	1	0204 vertical guide rod	2
	2	Recommendation guide	2

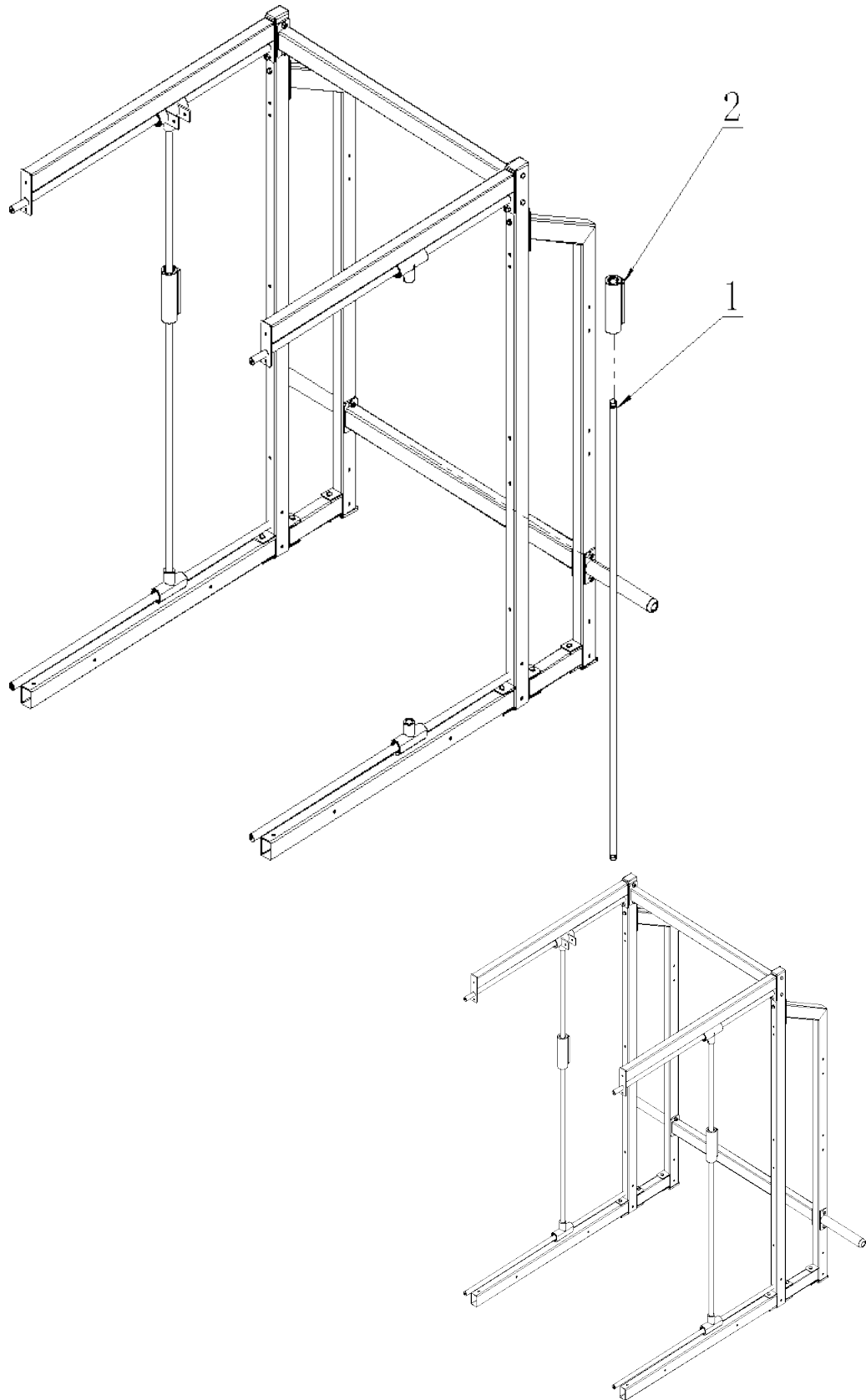

Step	Item No.	Name	Quantity
7	1	Front riser assembly	2
	31	0211 small round baffle	4
	B	Φ10 gasket	6
	F	M10X20L-W1 external hexagon head bolt	4
	J	M10X100L-W1 external hexagon head bolt	6
	Q	M10X9t-S1 lock nut	4

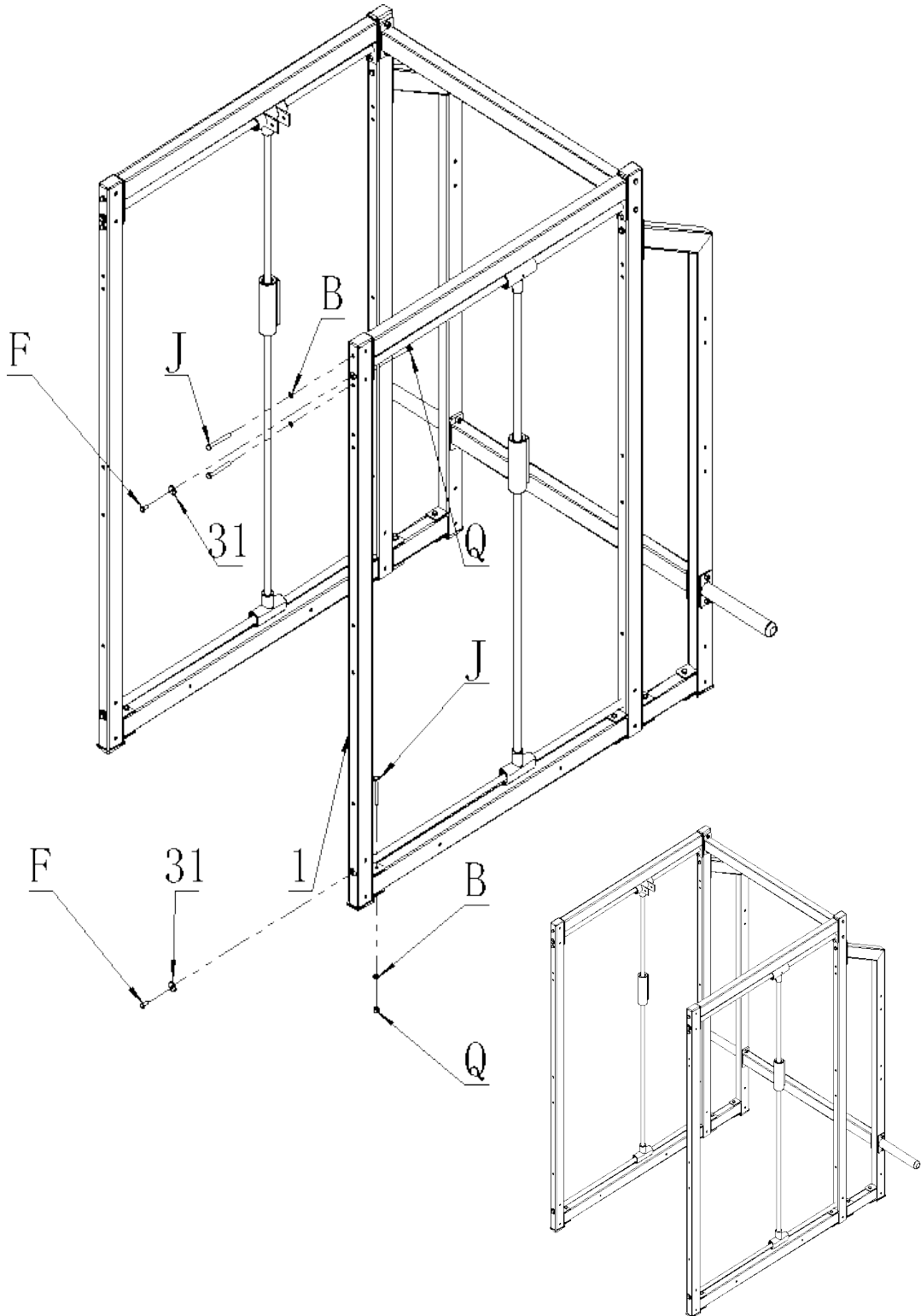

Step	Item No.	Name	Quantity
8	7	beam	1
	B	Φ10 gasket	4
	G	M10X70L-W1 external hexagon head bolt	4
	Q	M10X9t-S1 lock nut	4

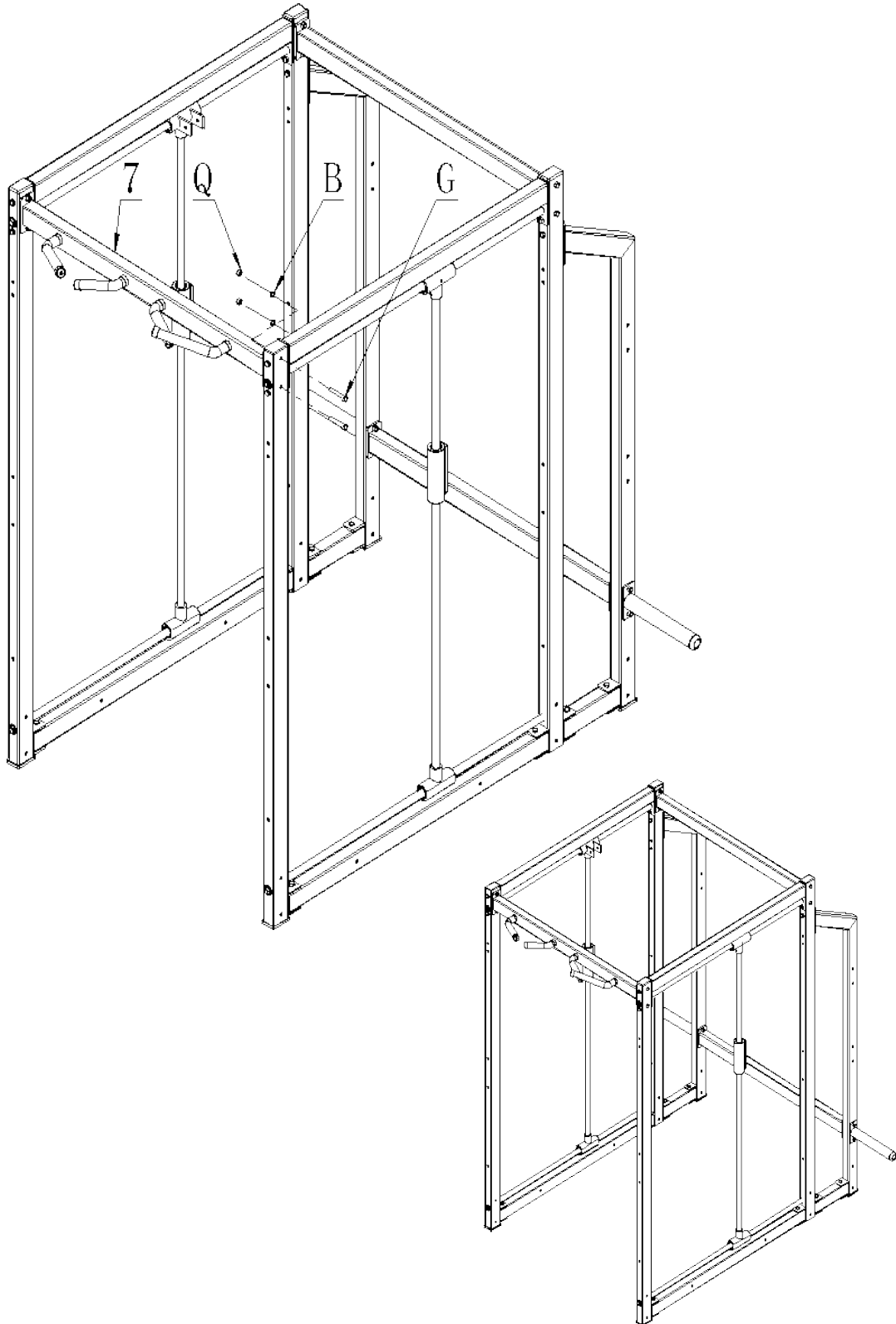

Step	Item No.	Name	Quantity
9	10	recommendation component	1
	16	linkage tube	1
	B	Φ10 gasket	2
	C	Φ12 gasket	4
	H	M10X80L-W1 hexagon head bolt	2
	N	M12X20L-N1 hexagon socket head screw	4
	Q	M10X9t-S1 lock nut	2

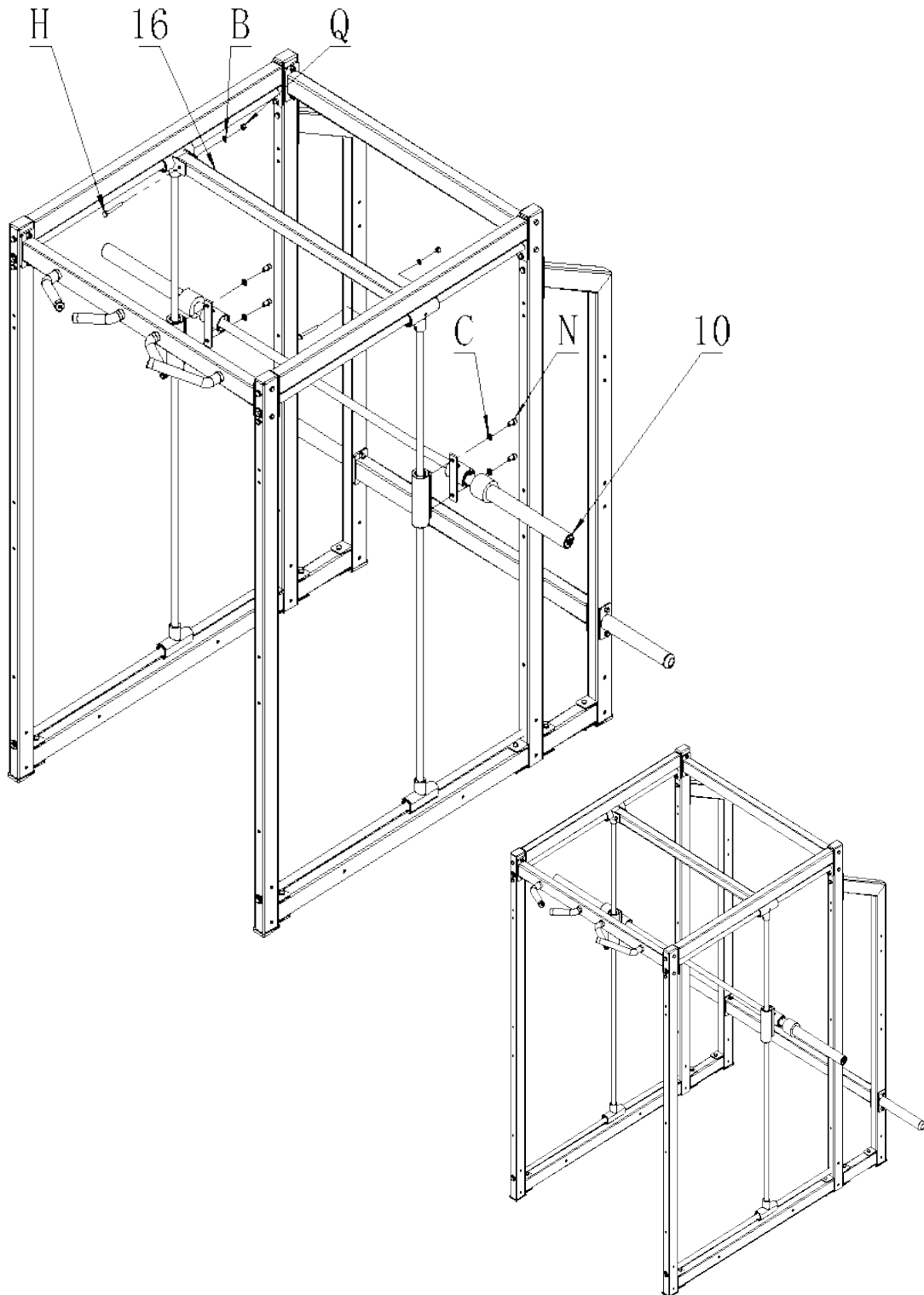

Step	Item No.	Name	Quantity
10	26	0404 guard plate	4
	B	Φ10 gasket	16
	G	M10X70L-W1 external hexagon head bolt	16
	Q	M10X9t-S1 lock nut	16

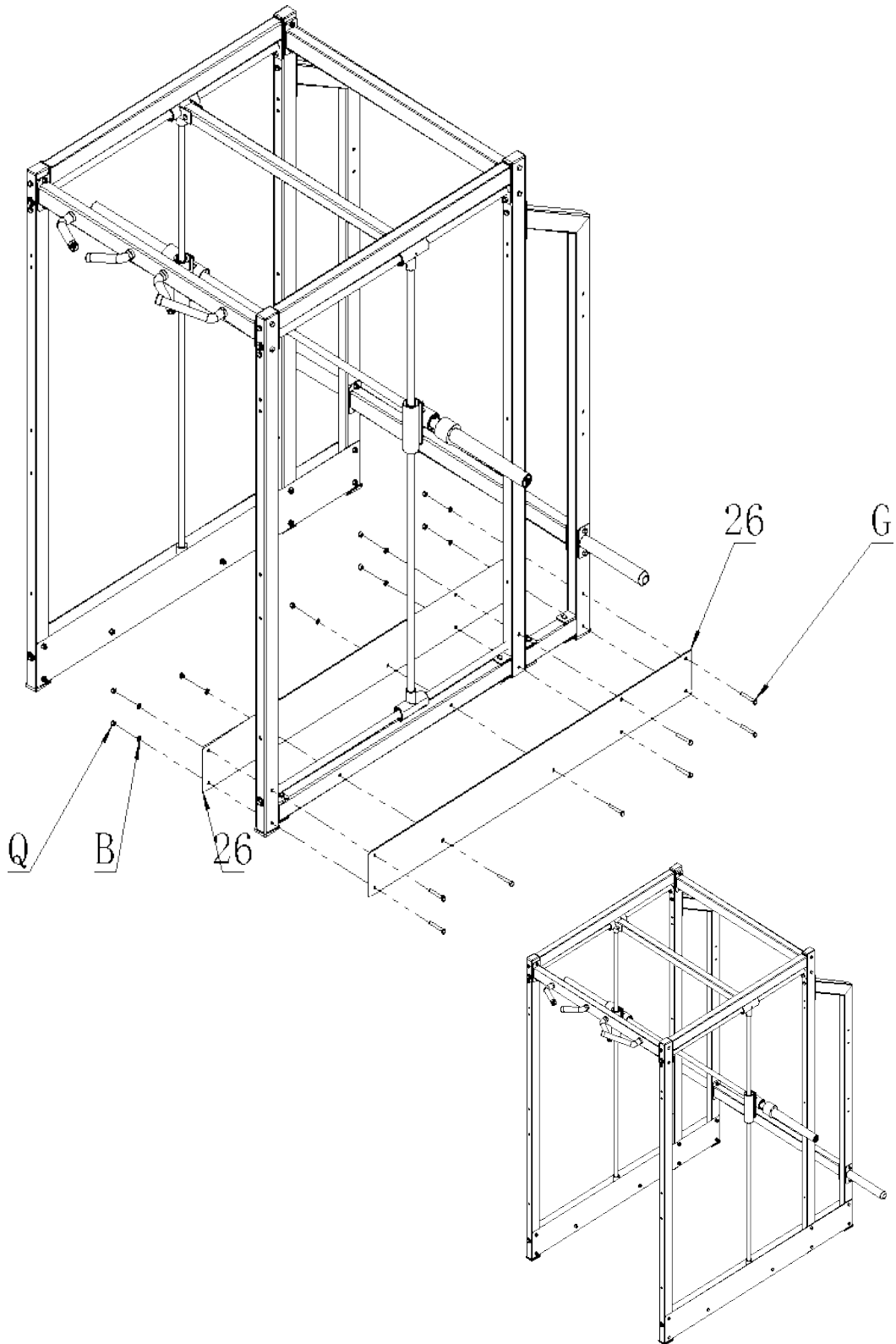

Step	Item No.	Name	Quantity
11	19	0401A stall hanging plate	1
	21	0402A gear mounting plate (narrow)	1
	23	0409 stall hanging plate	1
	25	gear mounting plate (narrow)	1
	B	Φ10 gasket	8
	J	M10X100L-W1 external hexagon head bolt	8
	Q	M10X9t-S1 lock nut	8

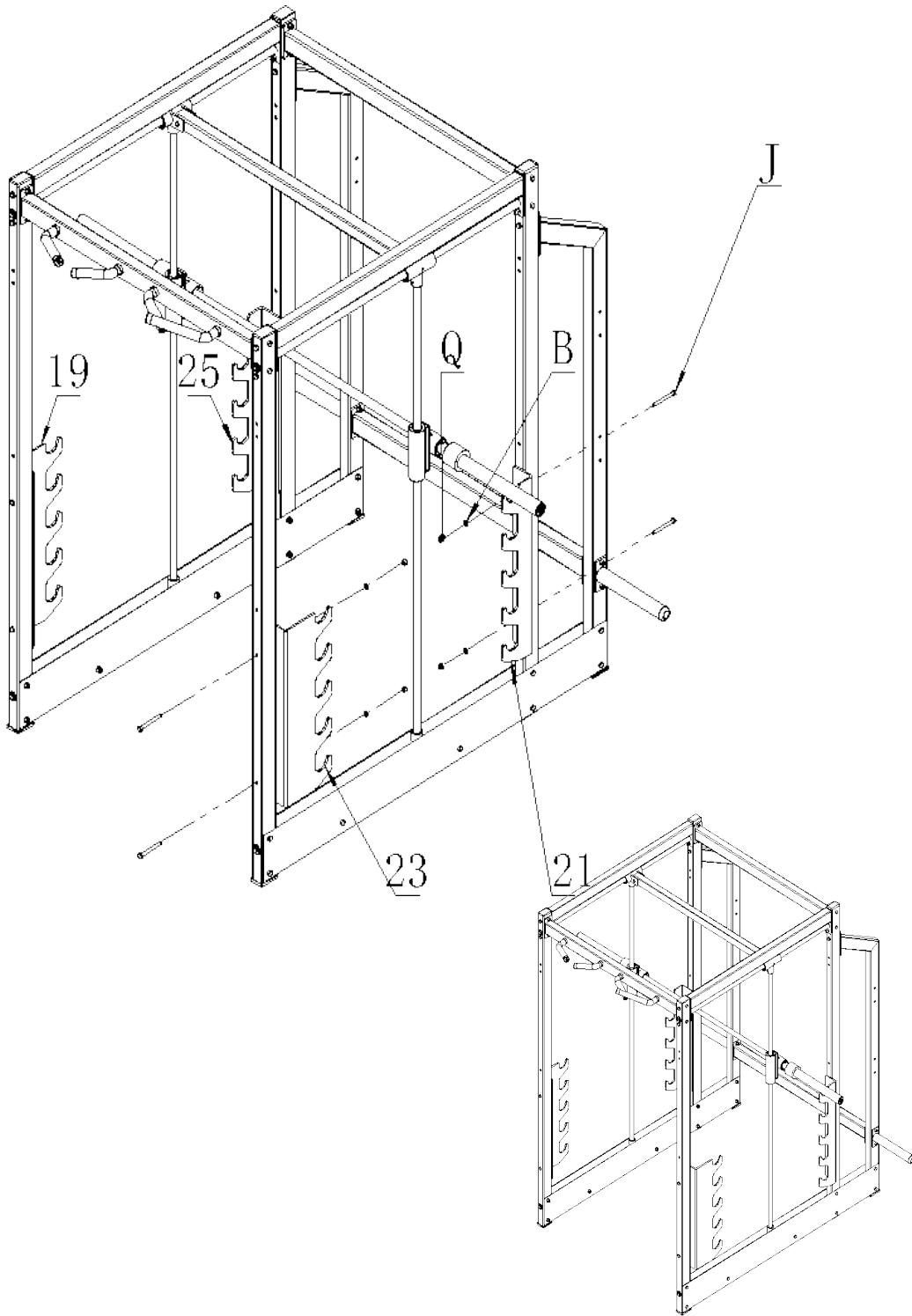

Step	Item No.	Name	Quantity
12	18	0401 stall hanging plate	1
	20	0402 gear mounting plate (narrow)	1
	22	0408 stall hanging plate	1
	24	0410 gear mounting plate (narrow)	1
	B	Φ10 gasket	12
	J	M10X100L-W1 external hexagon head bolt	10
	Q	M10X9t-S1 lock nut	12
	K	M10X110L-W1 external hexagon head bolt	2

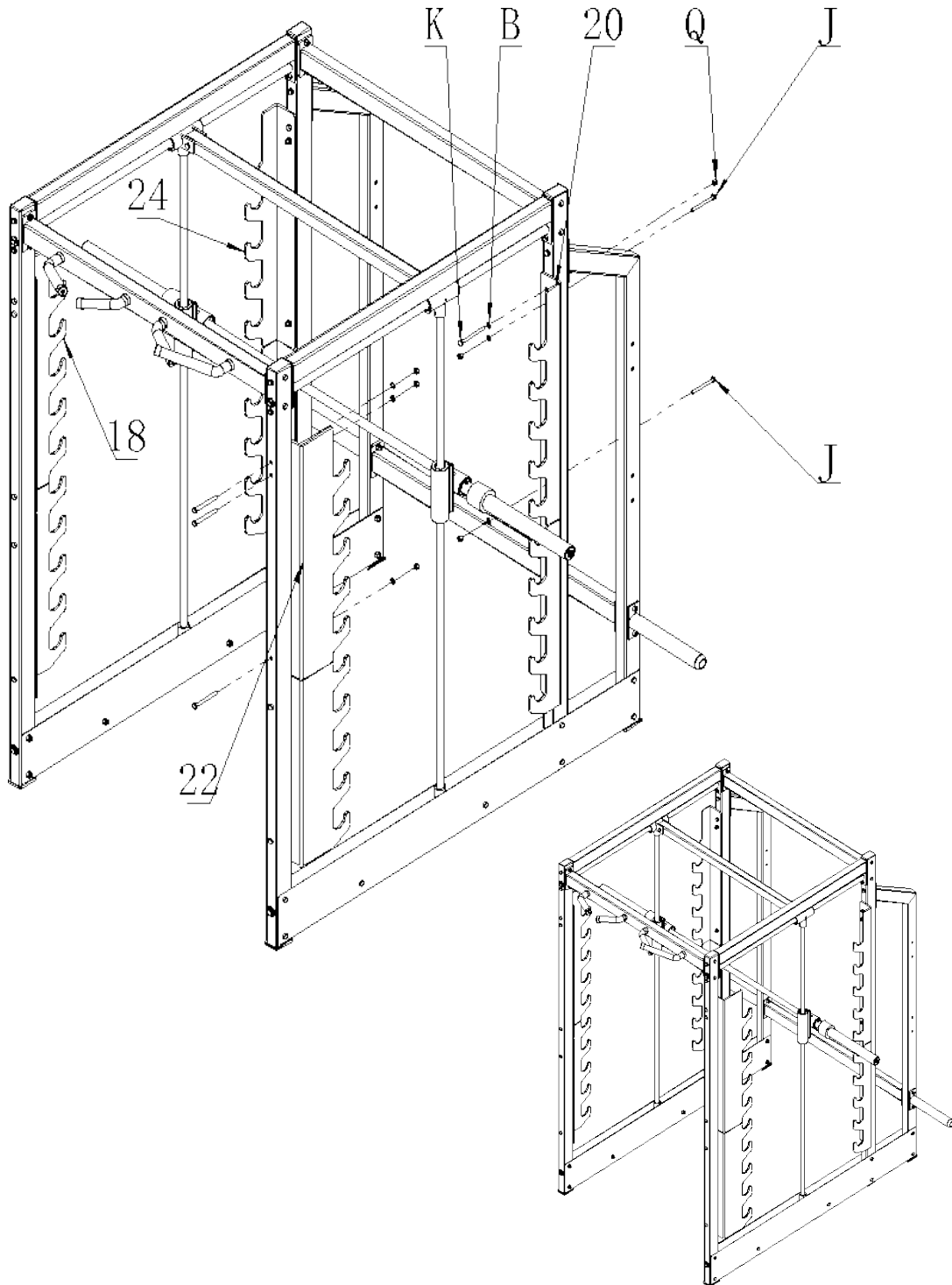

Step	Item No.	Name	Quantity
13	17	pipe blocking	2
	27	0407 guard plate	2
	30	0405 card shaft	4
	32	0114 nylon plate	4
	34	0114-1 nylon plate	4
	A	Φ8 gasket	4
	D	M8X16L-N2 hexagon socket head screw	8
	E	M8X40L-N2 hexagon socket head screw	4
	P	M8X7t-S1 lock nut	4

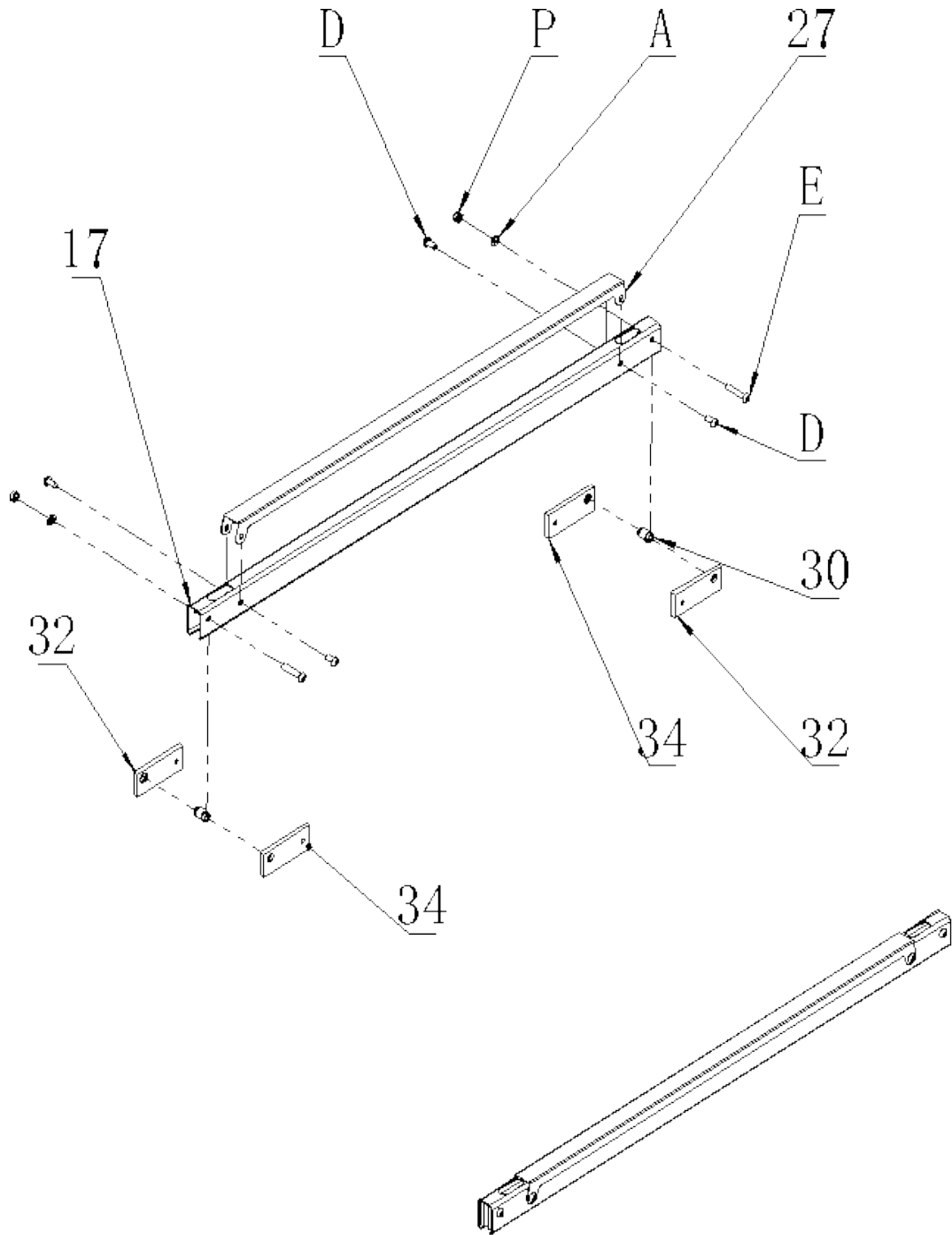

Step	Item No.	Name	Quantity
14			

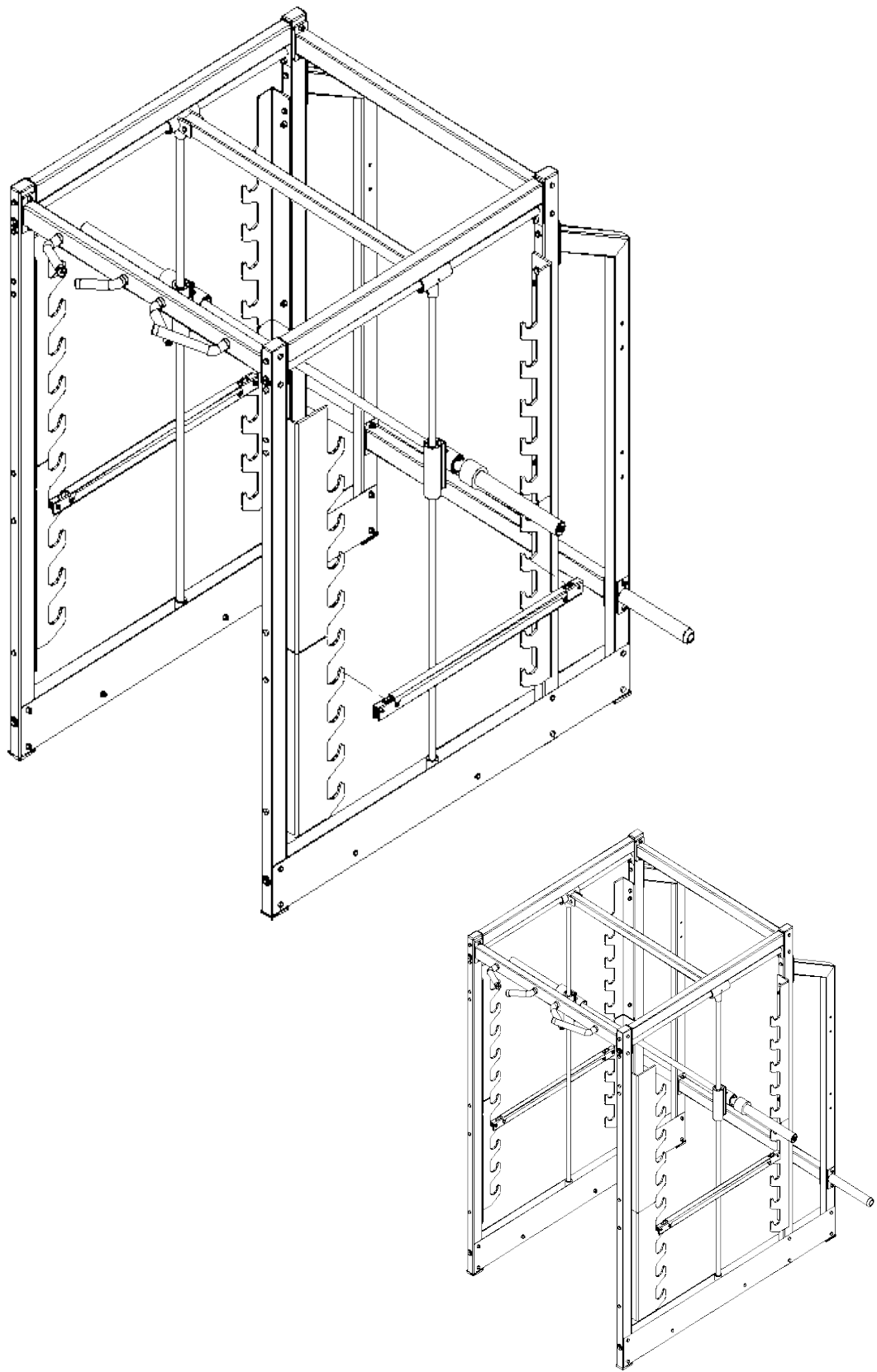

Step	Item No.	Name	Quantity
15	12	Barbell plate set	4
	B	Φ10 gasket	8
	L	M10X70L-N1 hexagon socket head screw	8
	Q	M10X9t-S1 lock nut	8

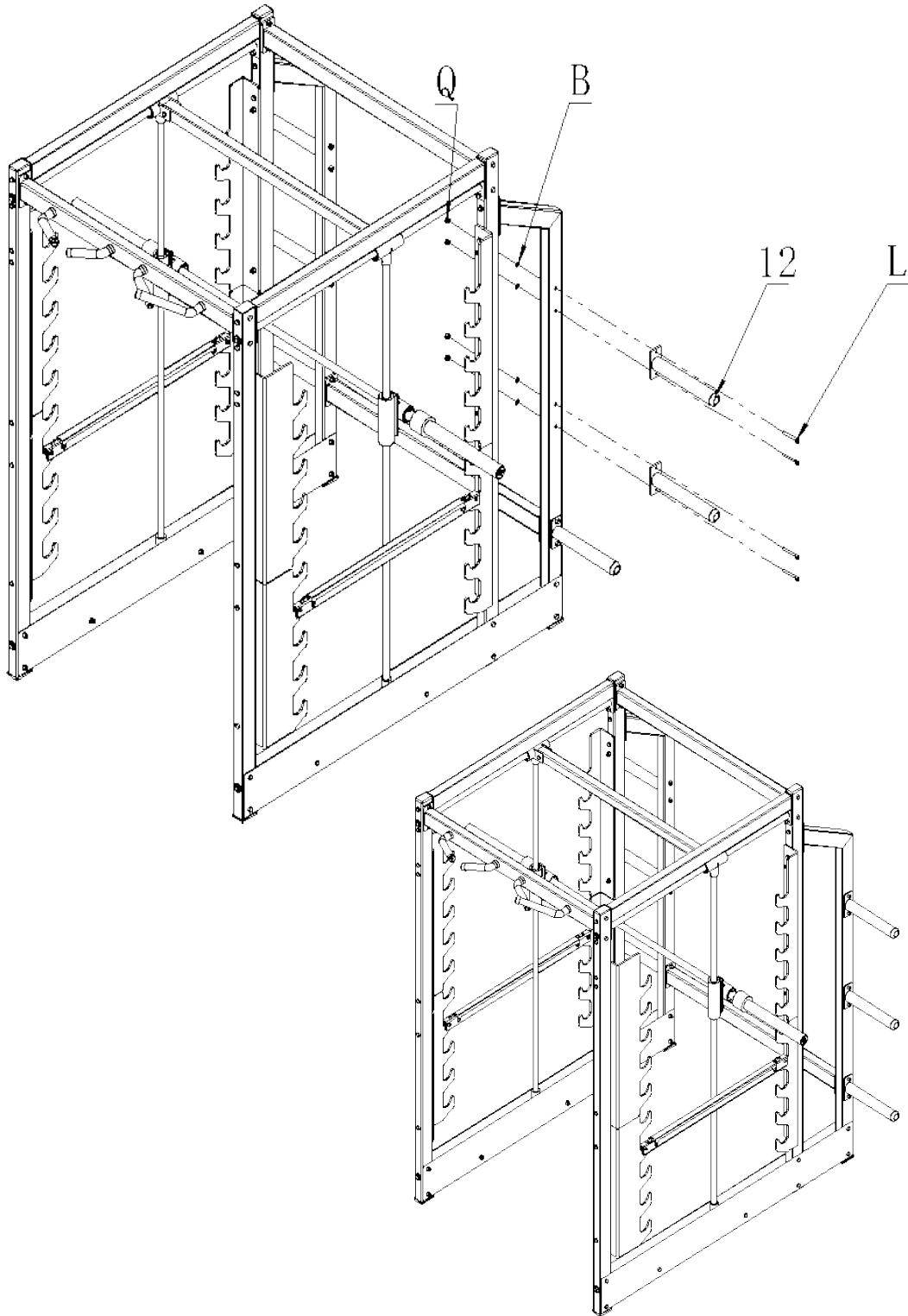

Step	Item No.	Name	Quantity
16	13	No. 120 decorative shock-absorbing pad	6
	33	No. 111 rubber ring	2

